

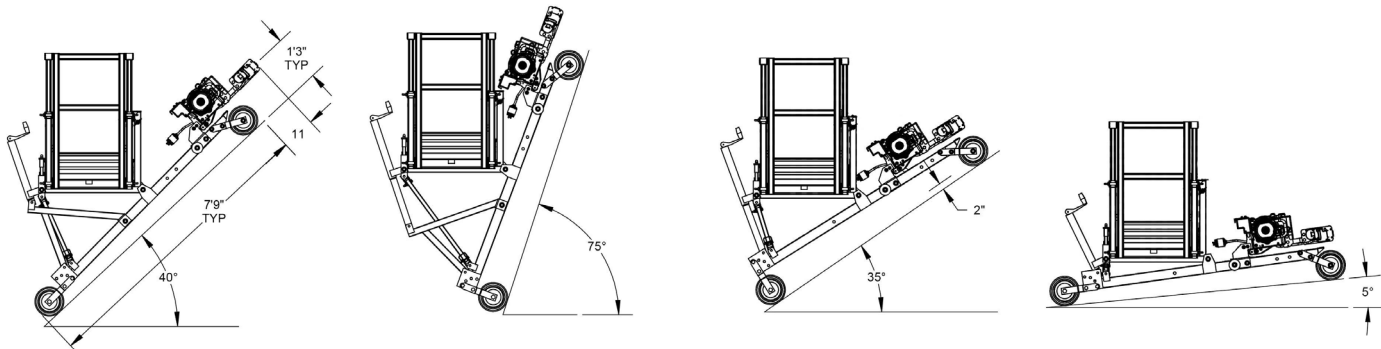

2145 Indian Road, West Palm Beach, FL 33409
Phone: 561.616.9003 www.beeaccess.com

SPEC-934111

INCLINE STIRRUP

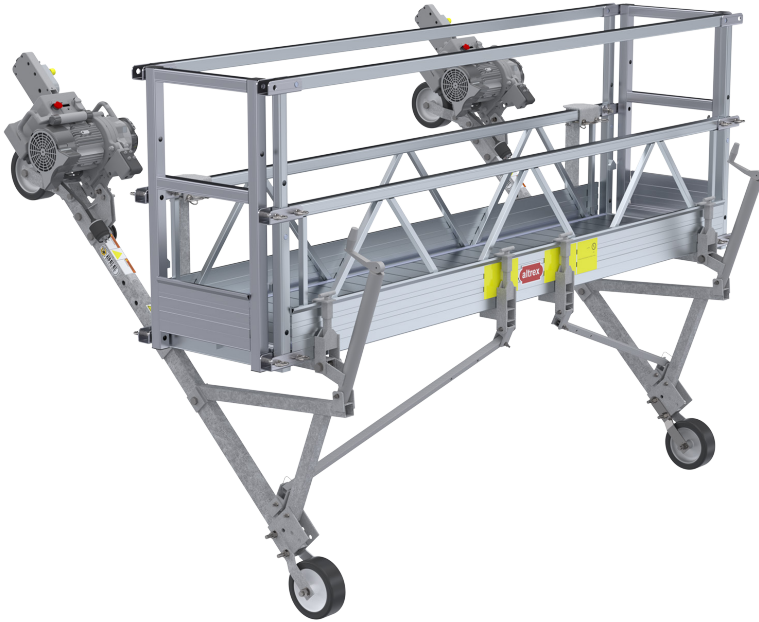

Demonstrates the Incline Stirrup with the jack support weldment, allowing level access to 40-75 degree surfaces.

Demonstrates the Incline Stirrup without the jack support weldment, allowing level access to 5-35 degree surfaces.

DESCRIPTION

The incline stirrup is ideal for dams, pyramid shaped buildings and other structures that are under an incline. The adjustments are infinite from 5-35 degrees or 40-75 degrees with supplied adapter bracket.

The incline stirrup is extremely versatile and can be mounted anywhere along the platforms' side frame. The hoist mounting bracket fits all popular traction hoists. Various wheel configurations are available.

SPECIFICATIONS

Part No.: 934139

Load Capacity: 1,500 lb

Dimensions: 82" x 9" x 7" (HxWxD)

Weight: 134 lb

Construction: Steel

Finish: Grey Powder Coating or Galvanized